



www.pumps.com.tw

GP-90

Domestic Centrifugal Pump AISI304 Hydraulic Parts & Optional 2 liter RO pressure tank

Liquid temperature: 5°C to 60°C / +41°F to +140°F
HP range: 1/4 HP / 200W
PH: 6 to 8
Rated Speed: 2900RPM (50Hz)/ 3500RPM (60Hz)
Insulation Class: F Class
Protection class: IP54



GPA-90S

HUNG PUMP GROUP

Home Booster

GP-90



Cast Iron Pump Casing with Brass Impeller

GP-90S



Stainless Steel Pump Casing with SS Impeller

GP-90S

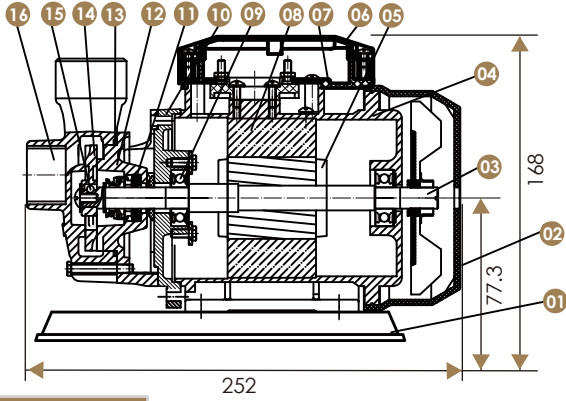

Construction (GP-90S)					
No.	Description	Material	No.	Description	Material
1	Base	PP+GF	9	Bearing	CNM5K
2	Fan Cover	PP(ST-031)	10	Bearing Upper Casing	FC200
3	Shaft	SUS410	11	Mechanical Seal	CA/CE
4	Motor Housing	Aluminum	12	Seal Plate	SUS304
5	Rotor	Silicon Steel	13	O-Ring	NBR
6	Capacitor Upper Cover	PP+UV	14	Impeller	SUS304
7	Capacitor Lower Cover	PP+UV	15	Key	SUS304
8	Stator	Silicon Steel	16	Pump Casing	SUS304

GP-90

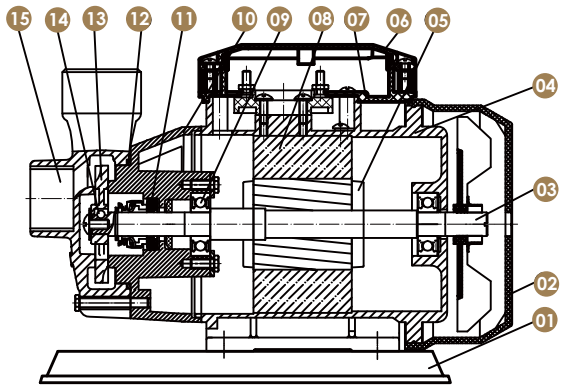

Construction (GP-90)					
No.	Description	Material	No.	Description	Material
1	Base	PP+GF	9	Bearing	CNM5K
2	Fan Cover	PP(ST-031)	10	Seal Plate	FC200
3	Shaft	SUS410	11	Mechanical Seal	CA/CE
4	Motor Housing	Aluminum	12	O-Ring	NBR
5	Rotor	Silicon Steel	13	Impeller	Copper
6	Capacitor Upper Cover	PP+UV	14	Key	SUS304
7	Capacitor Lower Cover	PP+UV	15	Pump Casing	FC200
8	Stator	Silicon Steel			

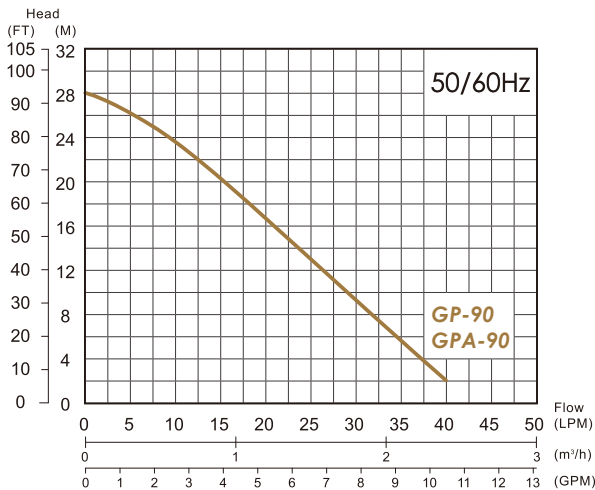

Specification													
Model No.	Power		Outlet		Max Flow (LPM)	LPM Flow @ Head					Max Head (M)	Dimension	Weight
	HP	W	mm	inch		5M	10M	15M	20M	25M		L x W x H (mm)	
GP-90(S)	1/4	200	25	1"	40	36	29	22	15	8	28	252 x 170 x 168	6.5
GPA-90(S)						36	29	22	15	8		260 x 212 x 333	8

Remarks: GPA-90 means with a pressure tank.